

## EQ & EQS ELECTRIC CHAIN HOISTS

### INCREASED PRODUCTIVITY



#### EQ

- ▶ 380 - 440 V
- ▶ 50 - 60 Hz
- ▶ 3 phases

---

#### EQS

- ▶ 110 V or 220 V - 240 V
- ▶ 50 Hz
- ▶ single phase



#### “No-load High-speed”

function: 1.3 times faster lifting speed when lifting less than 30 % of full load



## EQ & EQS electric chain hoist



### EQ

380 - 440 V  
50 - 60 Hz  
3 phases

### EQS

110V or 220V - 240V  
50 Hz  
single phase



### Frequency inverter as standard

For precise positioning of the load and  
“No-load High-speed” function



### “No-load High-speed” function

1.3 times faster lifting speed when lifting less than 30 % of full load.  
The EQS010IS even lifts due to its design 1.8 times faster  
at a maximum of 30 % of the nominal load



### Unique nickel-plated load chain

Grade T, series DAT (G80) in accordance with standard EN 818-7.  
Less wear and high corrosion resistance



EQ005 /  
EQS005

### Safety

- ▶ Frequency inverter controlled electronic overload protection and long-life friction clutch as mechanical overload protection
- ▶ Pull-rotor brake, extremely durable and reliable
- ▶ Operating hours counter / load cycle counter

### Features

- ▶ 24 V control voltage
- ▶ Operating temperature -20° C up to +40° C, max. 85% humidity
- ▶ Compact aluminium body, sealed (IP55 rated)
- ▶ Eye suspension

### Performance

- ▶ Dual lifting speed
- ▶ Up to 1,000 kg load capacity
- ▶ Maximum lifting height 15 m
- ▶ Upper and lower limit switch

### Options

- ▶ Top hook
- ▶ Radio remote control
- ▶ Safety load hook
- ▶ Plain or motor trolley (EQS only plain trolley)

### Radio remote control as option



# Benefits

## “No-load High-speed” function

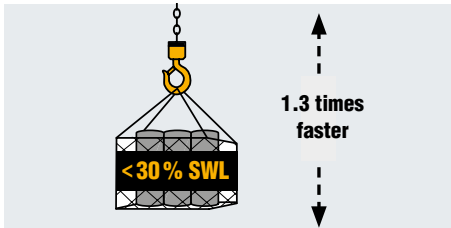

- ▶ 1.3 times faster lifting speed when lifting less than 30% of full load
- ▶ Improves work efficiency

## Dual lifting speed with inverter

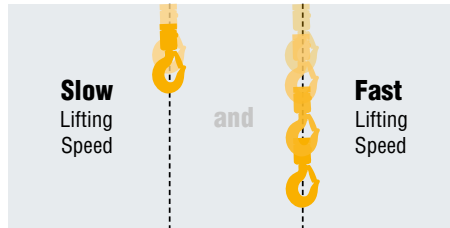

- ▶ High and low lifting speed
- ▶ Adjustable speed control
- ▶ Suitable for all work processes

## Unique load chain



- ▶ Less wear
- ▶ Higher corrosion resistance
- ▶ Longer lifetime, less down-times

## Frequency inverter



- ▶ Precise positioning
- ▶ Prevents load swing
- ▶ Increase safety
- ▶ Easy to use

## High FEM classification



- ▶ Up to 500 kg load capacity FEM 3m / ISO M6
- ▶ 1,000 kg load capacity FEM 2m / ISO M5
- ▶ High durability and reliability

## Reliable

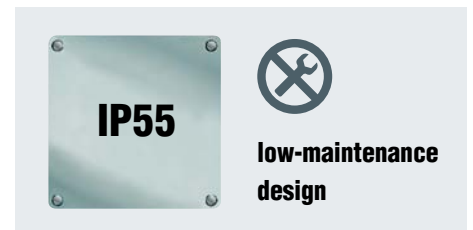

- ▶ Sealed die-cast aluminum body, IP55 rated
- ▶ No transformer, no electromagnetic components like contactors, relays, etc.

# Optional suspensions



**Top hook**  
▶ PAGE 8



**Plain trolley**  
▶ PAGE 9



**Motor trolley (only EQ)**  
▶ PAGE 10

## EQ & EQS Product description

### 1. Eye suspension

Offers low headroom. Suitable also for enclosed profile trolley applications. Easily changed to optional top hook.

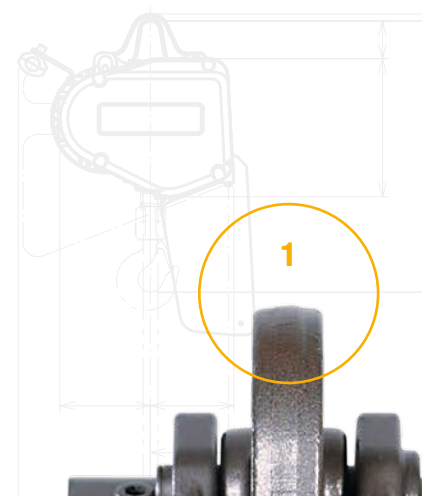

### 2. Load hook

With robust hook latch. Pivots by 360° provided by high quality ball bearings to avoid kinking and twisting of the load chain.

### 3. Compact die-cast aluminium body

Lightweight and completely sealed body, IP 55 rated. Compact design offers a low headroom.



### 4. Advanced pull-rotor brake

Extremely durable and reliable. Contains no brake coil to fail like conventional disc brakes.



### 5. Push button pendant

Ergonomic design. Easy-to-use in one-handed operation. IP65 rated. With emergency-stop button.



### 6. Fan-cooled motor

Heavy duty motor with external fan, cooling fins and external thermal motor protection. Improved air flow guarantees an optimized hoist duty rating and greatly lengthens brake life.

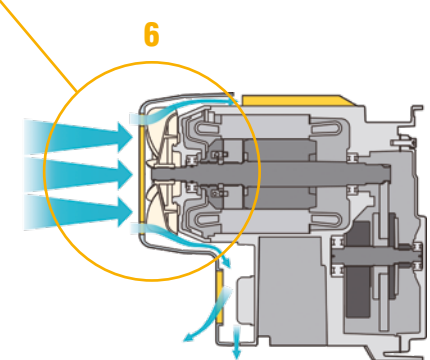

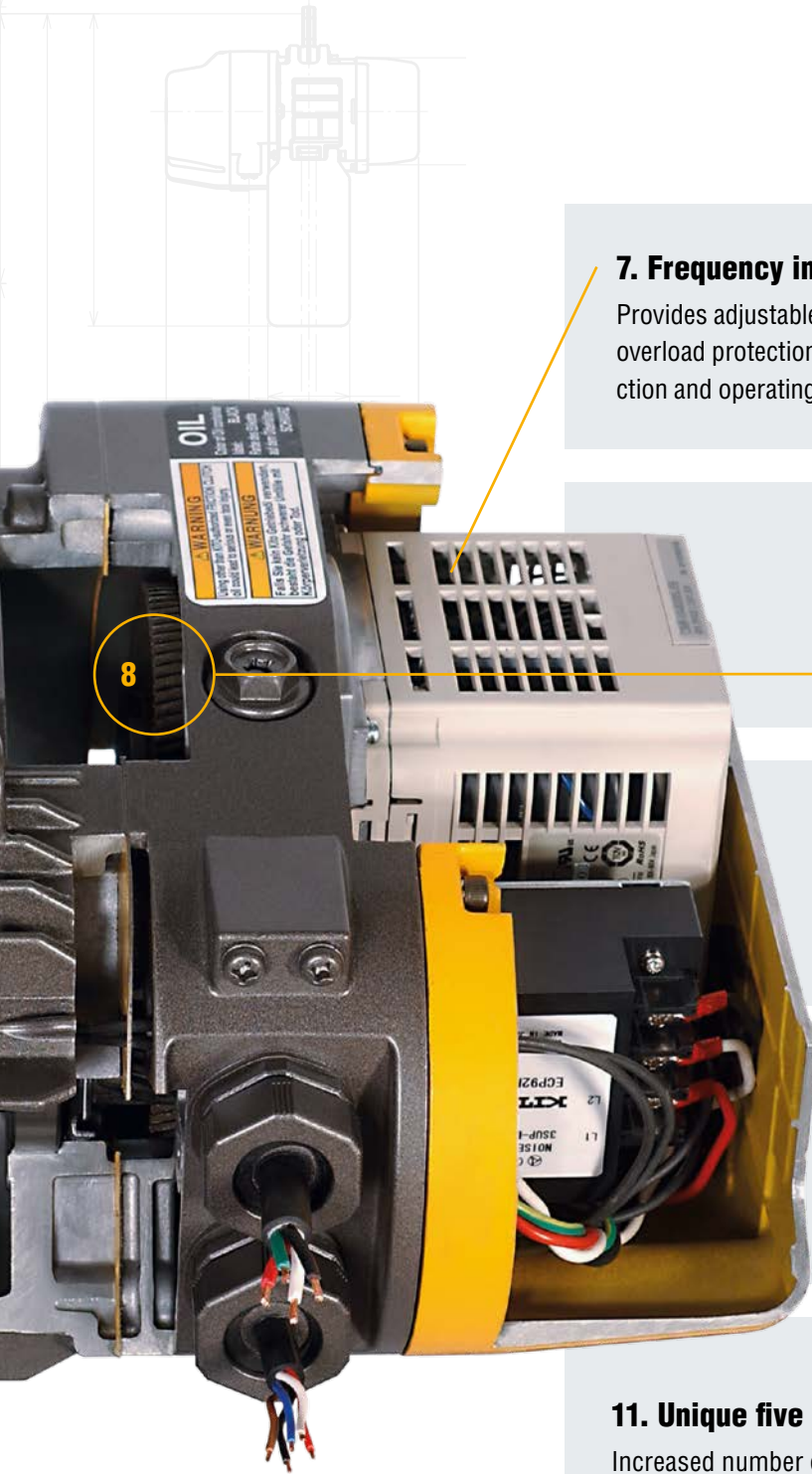

**7. Frequency inverter**

Provides adjustable dual lifting speed, overload protection, “No-load high-speed” function and operating hours counter. Speed ratio is 6:1.



**8. Helical gears**

Precision machined components guarantees quiet and smooth operation.

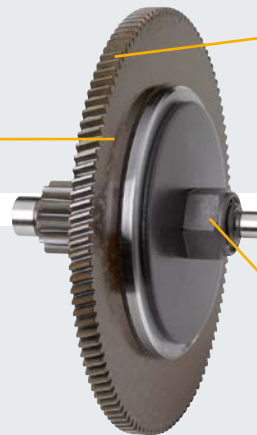

**9. Long-life friction clutch**

Provides consistent overload protection. Prevents damages of hoist and load.

**10. Unique Nickel-plated load chain**

Grade T, series DAT (G80) in accordance with standard EN818-7, strength 800 N/mm<sup>2</sup>. Less wear and higher corrosion resistance.

**11. Unique five pocket design**

Increased number of pockets reduces chain vibration and increases chain life. Five pockets as standard.



**12 + 13**



**12. Chain guide**

Provides smooth and quiet guiding of chain. Heavy cast iron construction for improved wear resistance.

**13. Upper & lower limit switch**

Robust micro switches. Low-profile design for an optimized headroom.

## EQ Applications

- ⚡ Industrial environment
- ⚡ Production facilities
- ⚡ Plant engineering
- ⚡ Assembly lines
- ⚡ Workshops
- ⚡ Marine equipment
- ⚡ Maintenance services
- ⚡ And many more ...





# EQS Applications

- 🔧 Construction sites
- 🔧 Maintenance services
- 🔧 Sewage industry
- 🔧 Workshops
- 🔧 Agriculture
- 🔧 Technical inspections
- 🔧 Production facilities
- 🔧 Assembly lines
- 🔧 And many more ...



### EQS

- ▶ 110V or 220V - 240V
- ▶ 50 Hz
- ▶ single phase



EQ

EQS

## Suspension eye EQ EQS

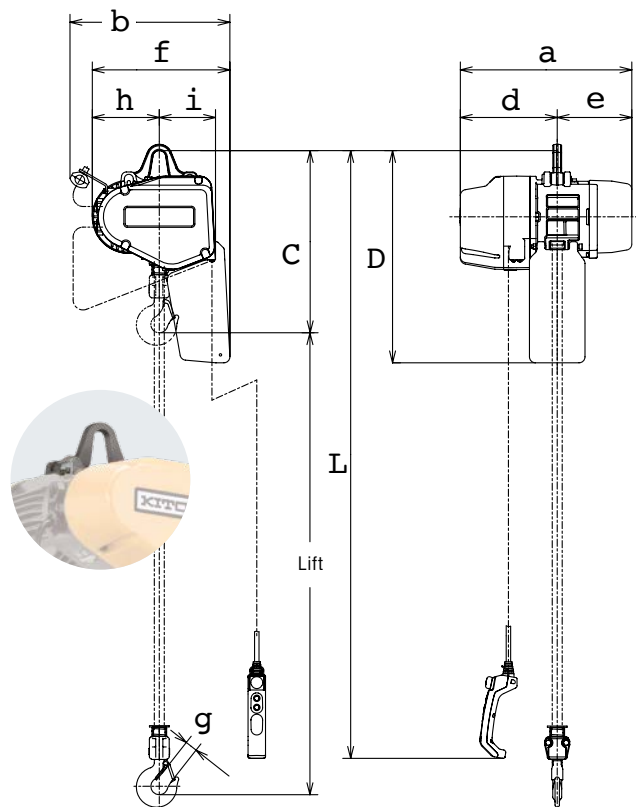

## Top hook EQ EQS

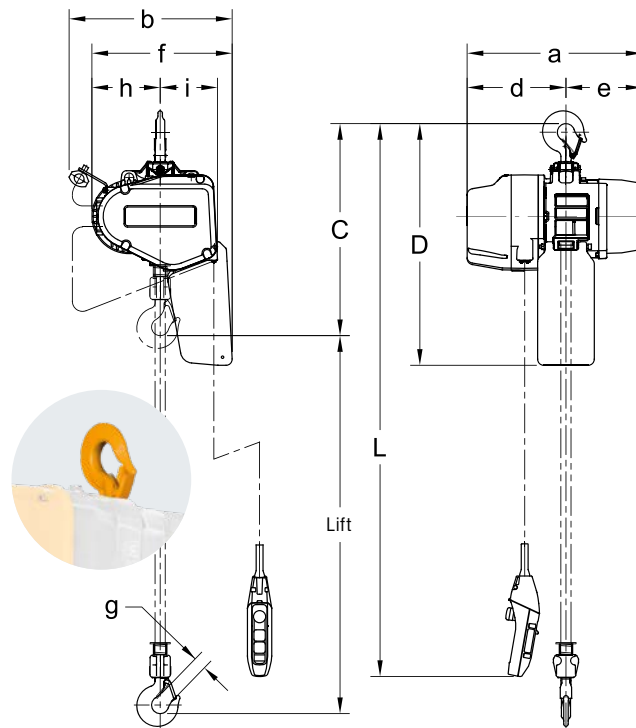

### Dimensions EQ / EQS

Basic	Type	Load capacity kg	Headroom C (mm)				Dimensions (mm)								
			C top hook	C suspension eye	D top hook	D suspension eye	a	b	d	e	f	g	h	i	
EQ	EQ001IS	125	440	395	533	485	417	367	230	187	298	27	137	128	
EQ	EQ003IS	250	440	395	533	485	417	367	230	187	298	27	137	128	
EQ	EQ005IS	500	458	410	533	485	417	367	230	187	298	27	137	128	
EQ	EQ010IS	1,000	525	465	598	535	433	403	245	188	332	31	154	142	
EQS	EQS005IS	500	458	410	533	485	417	367	230	187	298	27	137	128	
EQS	EQS010IS	1,000	525	465	598	535	433	403	245	188	332	31	154	142	

### Technical Data EQ / EQS

Basic	Type	Load capacity kg	Body size	Standard lifting height m	Lifting motor		Lifting speed, m / min			Load chain diameter mm	Chain falls	Classification FEM	Weight kg	Headroom C mm
					Output, kW	Rating, % ED	High (light load), 0 - 30%	High, 30 - 100%	Low					
EQ	EQ001IS	125	C	3	0.5	40 / 20	22.0	17.0	2.8	5.6 x 15.7	1	3m	32	395
EQ	EQ003IS	250	C	3	0.5	40 / 20	13.0	10.0	1.7	5.6 x 15.7	1	3m	31	395
EQ	EQ005IS	500	C	3	0.75	40 / 20	9.9	7.6	1.3	5.6 x 15.7	1	3m	32	410
EQ	EQ010IS	1,000	D	3	1.5	40 / 20	9.2	7.1	1.2	7.1 x 19.9	1	2m	42	465
EQS	EQS005IS	500	C	3	0.75	40 / 20	9.9*	7.6*	1.3	5.6 x 15.7	1	3m	33	410
EQS	EQS010IS	1,000	D	3	1.5	40 / 20	9.2**	5.1**	1.2	7.1 x 19.9	1	2m	43	465

\*% of full load, EQS005 speed ratio 6:1. \*\*EQS010 speed ratio 4:1, 1.8 times faster lifting speed when lifting less than 30% of full load.



# Plain trolley

EQ

EQS

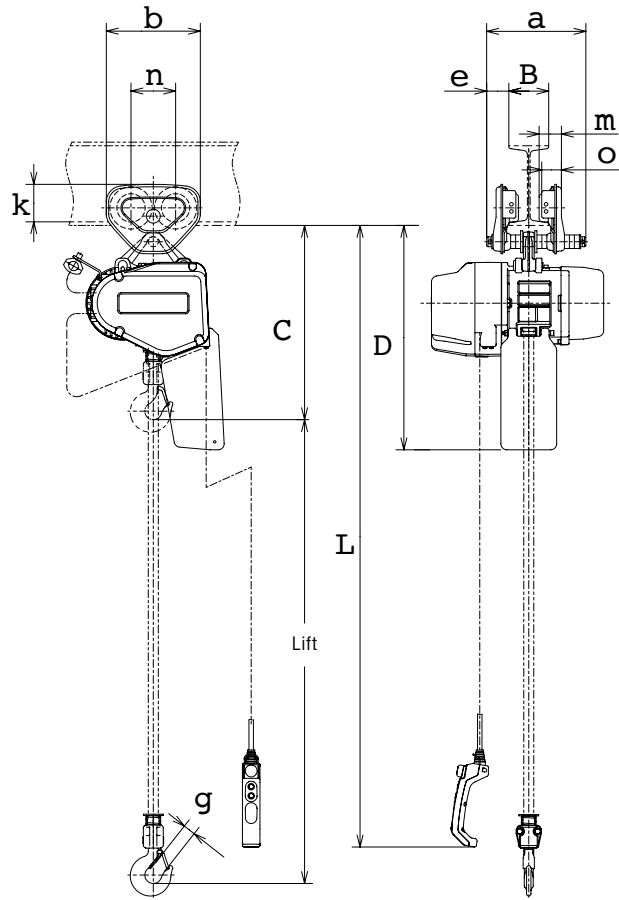
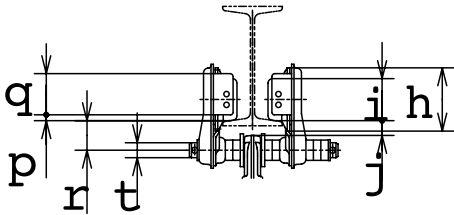

## Dimensions EQ / EQS with plain trolley

Basic	Type	Load capacity	Dimensions (mm)																
			kg	C	D	a	b	e	g	h	i	j	k	m	n	o	p	q	r
EQ	EQSP001IS	125	415	505	204	182	46	27	82	60	19	76	47.5	84	42	10	54	38	22
EQ	EQSP003IS	250	415	505	204	182	46	27	82	60	19	76	47.5	84	42	10	54	38	22
EQ	EQSP005IS	500	430	505	204	182	46	27	82	60	19	76	47.5	84	42	10	54	38	22
EQ	EQSP010IS	1,000	490	565	249	236	56	31	106	71	25	95	56	112	50	10	69	50	25
EQS	EQSP005IS	500	430	505	204	182	46	27	82	60	19	76	47.5	84	42	10	54	38	22
EQS	EQSP010IS	1,000	490	565	249	236	56	31	106	71	25	95	56	112	50	10	69	50	25

## Technical Data EQ / EQS with plain trolley

Basic	Type	Flange width B		Min. curve radius		Headroom C
		Standard (mm)	Option W30 (mm)	Standard (mm)	Option W30 (mm)	mm
EQ	EQSP001IS	50 - 163	164 - 305	1,150	1,200	415
EQ	EQSP003IS	50 - 163	164 - 305	1,150	1,200	415
EQ	EQSP005IS	50 - 163	164 - 305	1,150	1,200	430
EQ	EQSP010IS	58 - 163	164 - 305	1,350	1,400	490
EQS	EQSP005IS	50 - 163	164 - 305	1,150	1,200	430
EQS	EQSP010IS	58 - 163	164 - 305	1,350	1,400	490

## Motor trolley EQ

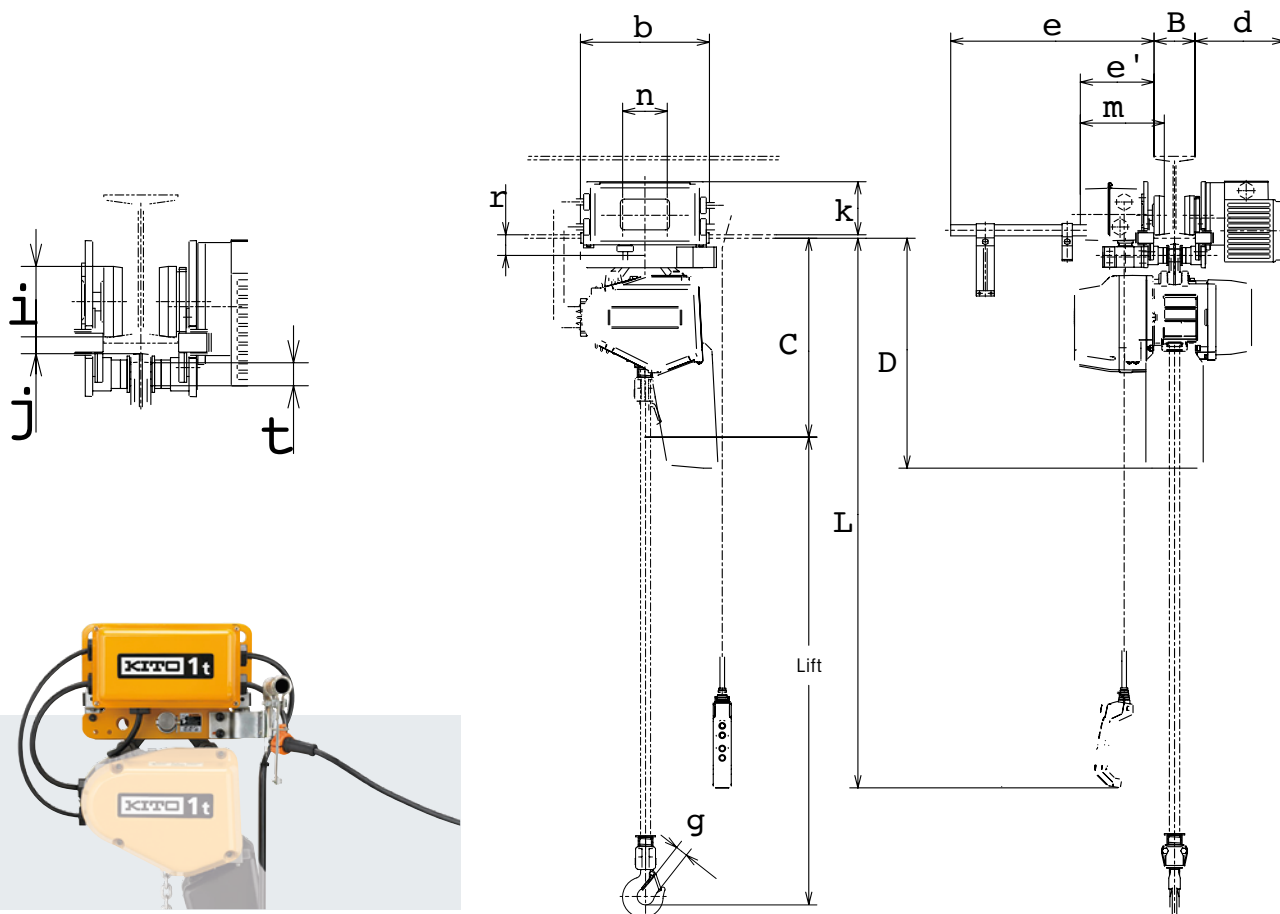

### Dimensions EQ with motor trolley

Basic	Type	Load capacity	Dimensions (mm)													
			kg	C	D	b	d	e	e'	g	i	j	k	m	n	r
EQ	EQM001IS-IS	125	420	515	315	220	515	179	27	95	27	130	205	109	51	31
EQ	EQM003IS-IS	250	420	515	315	220	515	179	27	95	27	130	205	109	51	31
EQ	EQM005IS-IS	500	440	515	315	220	515	179	27	95	27	130	205	109	51	31
EQ	EQM010IS-IS	1,000	490	565	315	220	515	179	31	95	22	130	205	109	51	31

### Technical data EQ with motor trolley

Basic	Type	Travel motor		*Travel speed (m/min)			Flange width B		Min. curve radius	Headroom C
		Output (kW)	Output (% ED)	Standard	50 Hz		Standard mm	Option W30 mm		
					High	Low			mm	mm
EQ	EQM001IS-IS	0.4	27/13	Standard	24	4	58 - 163	164 - 305	800	420
EQ	EQM003IS-IS	0.4	27/13	Standard	24	4	58 - 163	164 - 305	800	420
EQ	EQM005IS-IS	0.4	27/13	Standard	24	4	58 - 163	164 - 305	800	440
EQ	EQM010IS-IS	0.4	27/13	Standard	24	4	58 - 163	164 - 305	800	490

\*Adjustable travel speed: 24 / 2.4

# Chain container

EQ

EQS

In plastic or canvas, depending on lifting height.



**Plastic chain container**



**Canvas chain container**

Basic	Type	Load capacity	Plastic chain container	Canvas chain container
			kg	m
EQ	EQ001IS	125	6	15
EQ	EQ003IS	250	6	15
EQ	EQ005IS	500	6	15
EQ	EQ010IS	1,000	6	15
EQS	EQS005IS	500	6	15
EQS	EQS010IS	1,000	6	15

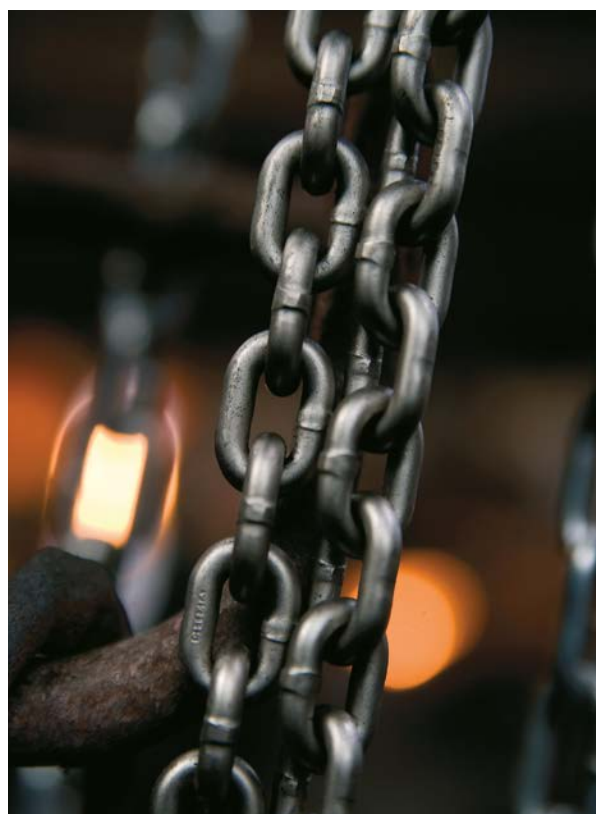

## Load chain

### Higher corrosion-resistance of the load chain

KITO is the only manufacturer worldwide offering electroless nickel-plated load chains. The advantages of these products are higher corrosion-resistance and lower wear compared to traditional load chains.

#### Further characteristics:

- ▶ Reduced hydrogen embrittlement
- ▶ Nickel-plated load chain grade T, series DAT (G80) as standard for electric chain hoists resp. grade T, series V (G100) as standard for manual chain hoists in accordance with standard EN 818-7
- ▶ Special manufacturing process – strength 800 N/mm<sup>2</sup> resp. 1,000 N/mm<sup>2</sup>

## Added value

### **KITO** weissenfels



Suits perfect to “below the hook devices” like chain slings from KITO Weissenfels

### **KITO** ERIKKILA



Unbeatable in combination with KITO ERIKKILA light crane systems and jib cranes

### **KITO** VAN LEUSDEN



On a high-quality level as engineered lifting solution from KITO VAN LEUSDEN

### **Kito Europe GmbH**

Heerdter Lohweg 93  
40549 Düsseldorf  
Tel.: +49 211 528 009-0  
info@kito.net

[www.kito.net](http://www.kito.net)  
[www.kitogroup.eu](http://www.kitogroup.eu)